

# Diesel Engines Series 40E

for Petroleum Applications

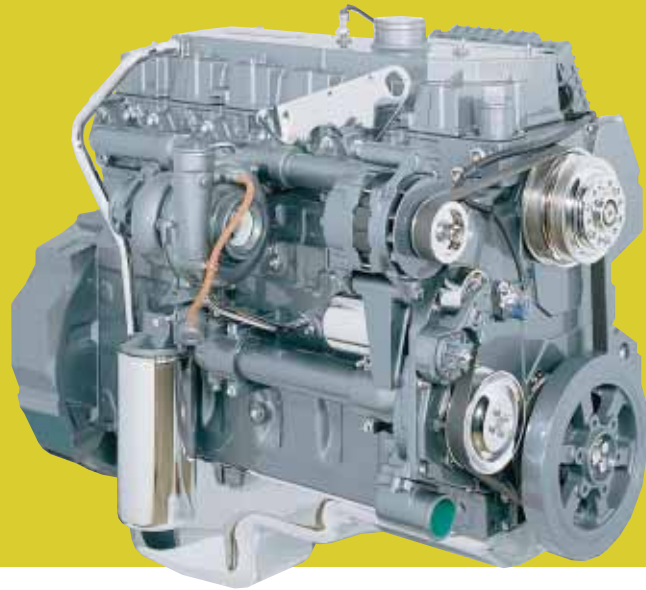

## Engine Specifications

Engine	7.6LT	8.7LT
Version	Inline 6 cylinder	Inline 6 cylinder
Displacement cu. in. (L)	466 (7.6)	530 (8.7)
Bore and Stroke, in (mm)	4.59 x 4.68 (117 x 113 )	4.59 x 5.3 (117 x 136 )
Governor	Fully Electronic HEUI	Fully Electronic HEUI
Length, in (mm)	44.69 (1135)	44.69 (1135)
Width, in (mm)	27.72 (704)	27.72 (704)
Height, in (mm)	39.61 (1006)	39.61 (1006)
Weight, lbs (kg)	1367 (630)	1399 (645)

## Detroit Diesel Power Built to Perform In Construction & Industrial Situations

The Series 40E is designed using the most advanced technology available today. The Series 40E is sold, serviced and supported by the Detroit Diesel Series 40 team headquartered in Detroit, Michigan, and by the network of Detroit Diesel distributors and dealers located throughout the world.

The Series 40E offers the single box, engine mounted electronic controls, utilizing the HEUI fuel system (Hydraulically actuated Electronically controlled Unit Injectors).

## Standard Power Rating

Power Output HP (kW)	bhp	kW	rpm
8.7LTE	265	198	2200
	265	198	2100
	265	198	2200
	300	224	2000
	300	224	2200
	315	235	2200
	330	246	2200



From the library of Barrington Diesel Club



# Technical Data

## Standard Equipment

- Belt tensioner – Polyvee serpentine belt
- Coolant conditioner
- Cylinder liners – Wet replaceable
- Electronic control – Engine mounted
- Fan drive – 15.1" height
- Flywheel housing – SAE #2
- Flywheel – SAE #2, 14" manual
- Fuel filter
- Hydraulically Actuated Electronically Controlled Unit Injectors (HEUI)
- Lube oil filter – Spin on full flow
- Oil cooler – Engine mounted
- Oil pan – Rear sump
- Rocker cover – Top inlet
- Turbocharger – Wastegate GT type

## Optional Equipment

- Air compressor – Bendix TuFlo 550  
Bendix TuFlo 750
- Alternator – Various
- Alternator bracket – Various
- Fan drive – Various
- Front mounts – Various
- Fuel filter – Remove accessory
- Oil pan – Various
- PTO adapter – SAE "B", 11 tooth
- Power steering pump – Various
- Pulleys – Accessory drive C/S
- Rocker cover – Side inlet
- Starter motor – Delco 37 MT (12 or 24V)  
Delco 42 MT
- Turbocharger – Reverse High mount
- Thermostat bypass – Vertical, Horizontal
- Water inlet – Various

For additional technical information, ratings, or performance data, consult your local distributor or dealer.

## Fully supported by the Detroit Diesel professional network

For more information contact your MTU distributor.  
All Detroit Diesel distributors in NAFTA are authorized MTU distributors. [www.mtu-online.com](http://www.mtu-online.com) / [www.detroitdiesel.com](http://www.detroitdiesel.com)  
[powergen@detroitdiesel.com](mailto:powergen@detroitdiesel.com)



From the library of Barrington Diesel Club

## Performance Curves - Series 40E 7.6 LT 330 BHP

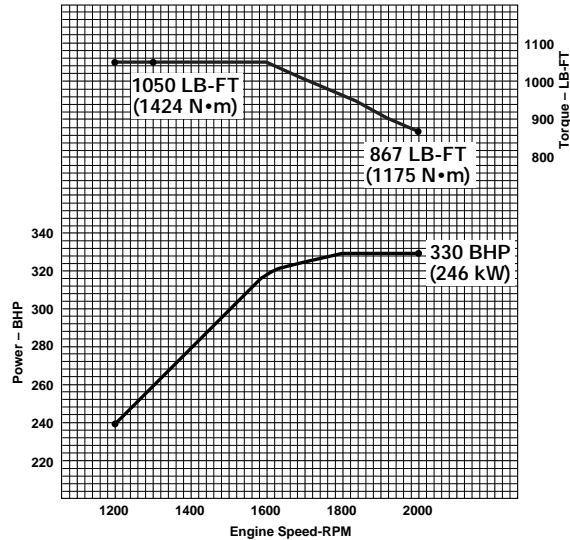

## Rating Explanation

Consult your authorized Detroit Diesel Corporation representative for the rating that will apply to your application.

Power Output guaranteed within 5% at SAE J1995 conditions.

## Dimensions - Series 40E 7.6 LT 330 BHP

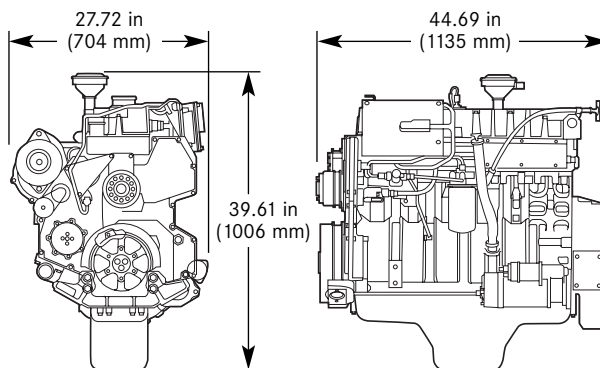

All dimensions are approximate. For complete dimensional information, refer to installation drawing provided by your authorized Detroit Diesel Corporation representative.