

## Tune-up Kit Model 25, 25B, 30, 30E, 400, 400H P/N 013950

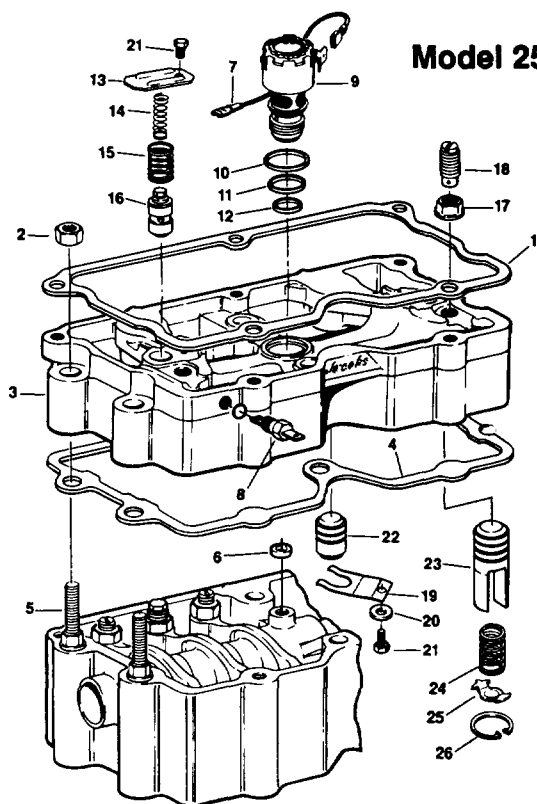

### Tune-up Kit Parts List

Ill. No.	P/N	Description	Qty.
1	013756	Gasket, valve cover	3
4	002610	Gasket, brake housing	3
6	010180	Seal ring	3
7	002390	Harness, solenoid	3
8	017657	Terminal assy. w/ o-ring	3
10	001081	Upper seal ring	3
11	001082	Middle seal ring	3
12	001083	Lower seal ring	3
14	007500	Inner spring - 30E, 400, 400H	6
14	001518	Inner spring - 25, 25B, 30	6
15	001519	Outer spring	6
16	011930	Control valve	6
19	011841	Flat spring - 25, 25B	6
19	007447	Flat Spring - 30, 30E, 400, 400H	6
20	001030	Washer	6
21	001492	Capscrew	12
NI	016467	Receptacle	3
NI	014646	Gasket, air intake aftercooler	1
NI	014647	Gasket, air intake non aftercooler	1
NI	017653	Instructions	1

Fig. 1

## Instructions

For additional information on the models 25, 25B, 30, 30E, 400 and 400H engine brakes refer to Jacobs Engine Brake Installation Manual P/N 012323.

Use OSHA approved cleaning solvent for cleaning parts. Original parts to be reused should be inspected for wear and replaced as required. Wear safety glasses where indicated.

### Access Engine Brake

1. Thoroughly clean engine.
2. Remove air intake manifold connection and discard gaskets.
3. Disconnect electrical connections to the engine brake housings.
4. Remove in this order: rocker lever covers, housing hold-down nuts (2) and engine brake housings (3).
5. Remove and discard engine brake housing gaskets and rocker cover gaskets (1,4) and oil seal rings (6) from bottom of housings.

### Disassemble Housings

1. Remove the solenoid harness (7) and valve (9); discard harness and three seal rings (10, 11, 12).
2. Remove and discard terminal lead out assemblies (8).



**Control valve covers (13) are under tension from control valve springs (14, 15). Remove covers carefully and wear safety glasses.**

3. Hold down on control valve cover while removing the capscrew. Remove and discard springs, control valves (16) and capscrews (21). Save control valve covers.

4. Remove master piston (22); discard flat spring (19), washer (20) and capscrew (21). Save the master piston.



**Slave pistons (23) are retained by heavy springs (24). To avoid injury when removing the slave piston, use proper tools and wear safety glasses.**

5. Remove locknut (17) from slave piston adjusting screw (18) and back out screw until the slave piston is fully retracted.
6. Install the slave piston tool P/N 017397 (Fig. 2) with the adjusting screw fitted into the hole in the tool.
7. Compress the slave piston spring and remove the retaining ring (26).
8. Remove the retainer (25), spring, slave piston and adjusting screw.

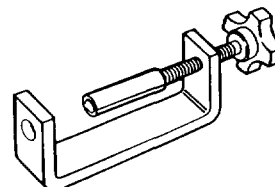

Fig. 2

### Assemble Housings

1. Clean housings and all parts in cleaning solvent. Dry with compressed air.
2. Coat all parts to be installed into housings with clean lube oil.
3. Install the original slave piston, reversing the removal procedure.

**NOTE: Before removing the slave piston fixture, rotate the retaining ring 90 deg. from the slot in the housing.**

4. Remove the fixture and install the adjusting screw locknut.
5. Install new control valves and springs. Use original control valve covers and new capscrews.
6. Install original master pistons with new flat springs, washers and capscrews.

**NOTE: When tightening screw, be sure that spring legs are centered around master piston boss.**

7. Install the lower (smallest) solenoid seal ring in the bottom of the solenoid valve bore and the upper and center seal rings on the solenoid valve. Insert the solenoid valve into the bore. Tighten to 5 lbft. or 60 lbin. (7 N-m).
8. Install a new terminal lead out assembly into each housing. Tighten with a sixpoint box wrench until seated.
9. Connect new wire harness from the solenoid valve to the terminal lead out assembly.

**NOTE: If the wire connector on the solenoid is not the correct type, replace with ones from the kit.**

### Install Engine Brake Housings

1. Install the oil seal ring in the bottom of the housing.
2. Set the engine brake gaskets on the rocker lever housings. Place the engine brake housings on the rocker lever housings.
3. Install the housing hold-down nuts. Tighten the nuts to 60 lbft. (80 N-m), following the sequence shown in Fig. 3.

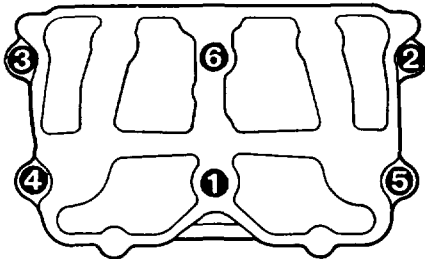
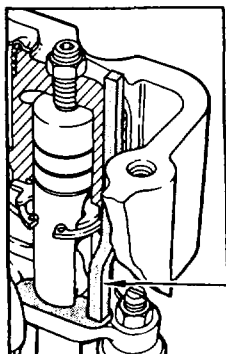

Fig. 3

### Adjust Slave Pistons

**NOTE: Make slave piston adjustments with the engine stopped and cold. Exhaust valves must be in the closed position (crossheads loose).**

1. Insert the .018 in. (0.46 mm) feeler gauge, P/N 003087, between the crosshead and slave piston. Turn the slave piston adjusting screw in until a slight drag is felt on the feeler gauge. See Fig. 4.
2. Hold the adjusting screw and torque the locknut. Torque earlier model 30Es with 3/8 - 24 screw to 16 lbft. (22 N-m);



Feeler Gauge Fig. 4

all other models and 30Es with 1/2 - 20 screws, should be torqued to 25 lbft. (35 N-m).

3. Adjust the clearance on the remaining cylinders in firing order.

### Finish Engine Brake Installation

1. Attach the lead wires to the lead out assemblies on the outside of the housings.
2. Install new rocker lever gaskets and rocker lever covers; tighten the screws.
3. Install the appropriate new air intake manifold gasket and the air intake connection.

### Jacobs Engine Brake Replacement Part Limited Warranty

Jacobs Engine Brake replacement parts, products of the Jacobs Manufacturing Company, are sold with the following warranty.

Jacobs Engine Brake replacement parts are warranted to be free of defects in construction and operation under normal use and service for the warranty coverage periods set forth below.

THERE ARE NO REPRESENTATIONS OR WARRANTIES WHICH EXTEND BEYOND THE TERMS HEREOF OR THE DESCRIPTION OF THE PRODUCT CONTAINED IN THE CONTRACT FOR SALE.

#### Warranty Coverage:

Replacement parts are warranted for 3 months or 24,000 miles (28,600 kilometers), whichever shall first occur. Replacement parts installed during the original warranty coverage period for a Jacobs engine brake are warranted as stated in the Jacobs engine brake warranty.

Under this warranty our factory is obligated to replace, without charge, any part returned to us which our examination discloses to our satisfaction to have been defective within the Warranty coverage period measured from the date of delivery of the product in question to the original user.

Jacobs will also pay for all repairs to damaged engine components in which Jacobs replacement parts have been properly installed, provided the damage is shown to be a direct result of a defect of Jacobs replacement parts occurring under normal operation during the warranty coverage periods specified above.

This warranty will not apply to any part or parts which have been altered or repaired outside of our factory or authorized Jacobs distributor service centers, nor to parts which have been subjected to misuse, abuse, neglect, or accident, nor to parts which have been improperly applied or installed. Improper installation or application, or substitution of parts not manufactured or approved by us, shall void this warranty.

JACOBS' SOLE LIABILITY AND YOUR EXCLUSIVE REMEDY IS LIMITED TO THE OBLIGATIONS SET FORTH HEREIN, AND JACOBS SHALL NOT BE LIABLE FOR ANY SPECIAL, INDIRECT OR CONSEQUENTIAL DAMAGES.

J. Jacobs®, Jake Brake® and Auto-Lash® are registered trademarks of  
The Jacobs Manufacturing Company.  
Jake is a Marc. Reg. in Mexico